

Kappa Duofix Under Counter Concealed Cistern

GEBERIT

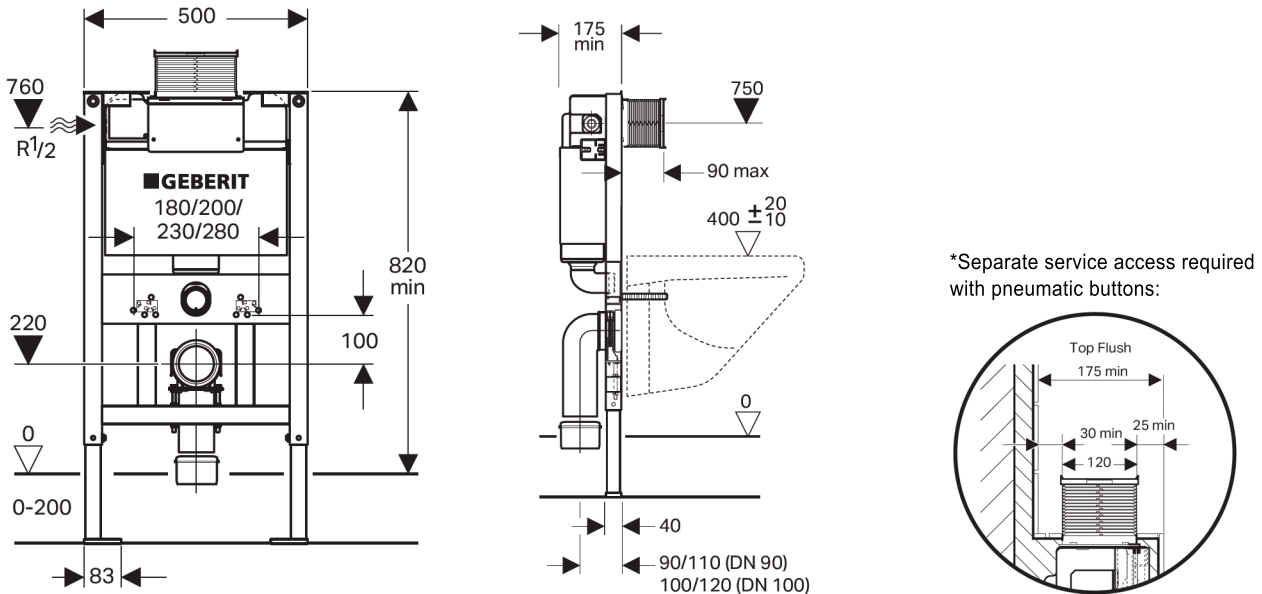

Features

High density, impact resistant one-piece blow moulded HDPE tank.

25-year spare parts availability and the 15 year warranty on Geberit cistern tanks and frames provides long-term security.

The dual-flush plate acts as the button and provides the access required for servicing the internal parts of the cistern.

Strong, stable and easy to service: each frame is tested to withstand 400kg of weight.

Designed in Switzerland.

Specifications

Article No.	111.262.00.1 (6/3L) 111.263.00.1 (4.5/3L)
Installation type	Low height in-wall or in vanity
WELS rating	3 Star (6/3L) or 4 Star (4.5/3L)
Pan type	Suits major wall hung pans
Standards	Watermark
Operating pressure	10-1000Kpa
Operation	Front or top flush
Warranty	15 years on cistern tank and frame, 3 years on valves
Compatible buttons	Kappa20, Kapa21, Kappa50, Remotes* - in vanity, Sigma plates with Sigma adapter

Geberit Pacific Head Office
Unit 8a, 6-8 Byfield Street
Macquarie Park NSW 2113

T 1800 GEBERIT
F 02 9889 7855
sales.au@geberit.com

> [geberit.com.au](https://www.geberit.com.au)

BATHROOM COLLECTIVE

Phone Number: (02) 9011-5711