

Grid Type 3

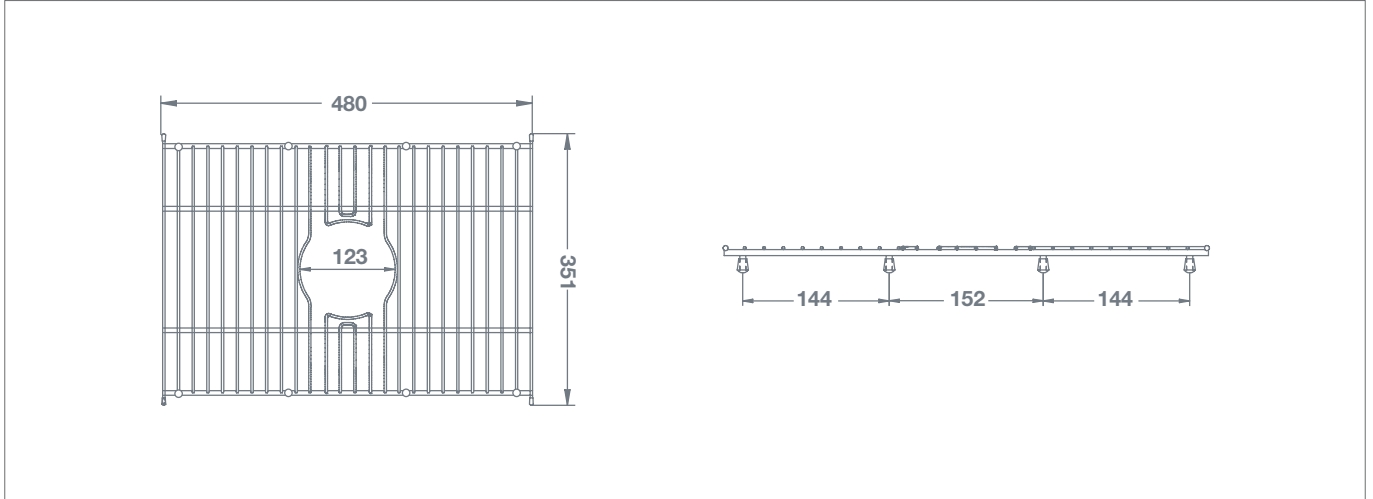

		Dimensions			
Grid Type 3	FT0300010	(mm)	480	351	26



BATHROOM COLLECTIVE

Phone Number: (02) 9011-5711

Features include:

- Added protection, designed specifically for Shaws sinks.
- Doubles as a draining rack.
- Rigid and durable 304 grade stainless steel sink grid.
- Non-slip black rubber feet.
- Suits Butler 600, Bowland 600, Shaker Single 600, Inset 600 and Lancaster 600 Single Bowl and Whitehall sinks.
- 12 month warranty. Visit Shaws website for more details.