

# Calibre Twin rail shower

# SUSSEX

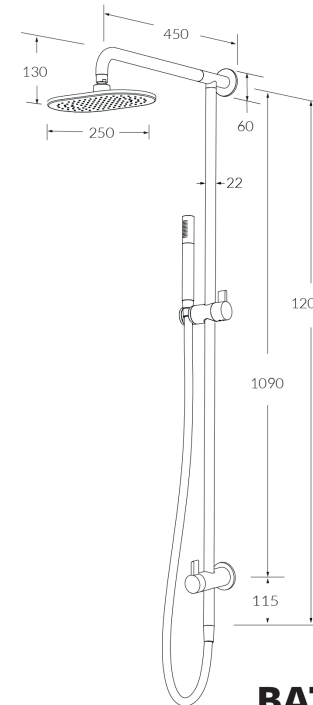

## BATHROOM COLLECTIVE

Phone Number: (02) 9011-5711

### Product code

CTRS

### Product features

- Designed and manufactured in Australia
- All brass construction
- Fixed handle lever
- Dial operating diverter
- Swivel ball joint
- Retro fitable
- Available in a range of high quality, durable finishes inc. LUXPVD®
- Minimal, refined design to complement any contemporary space
- Matching tapware and showers

### Warranty

15 Years  
Shower head and arm.  
3 years for rail showers.  
2 years for shower hoses.

### Pressure rating

300 - 500kPa

### Temperature rating

1 - 65°C

### WELS rating

3 star - 8lt/min

